

NOW AVAILABLE
AT IP66 RATING

Fast Fit

3 phase distribution boards



Fast Fit

Designed for easy installation and fast wiring

clipsal.com



We've opened our doors
to commercial

4 SERIES

consumer switchboards

The Clipsal 4 Series already includes an extensive selection of consumer switchboards and components, although these are generally for domestic applications.

Now the range has been expanded to include heavy-duty 3 phase distribution boards for commercial and industrial use.

Specifically designed to house the comprehensive Clipsal Power Range of MCBs, these distribution boards provide facilities for either DIN rail or gear tray installation. Models from 18 to 84 poles are available, all featuring an abundance of interior room to help with wiring and installation.

The new products are made from durable zinc anneal steel of at least 1.2mm, in powdercoated grey or orange to suit most commercial and industrial applications.

Easy installation.
Spacious interior.
Specials available.

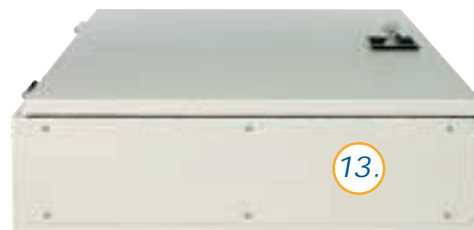
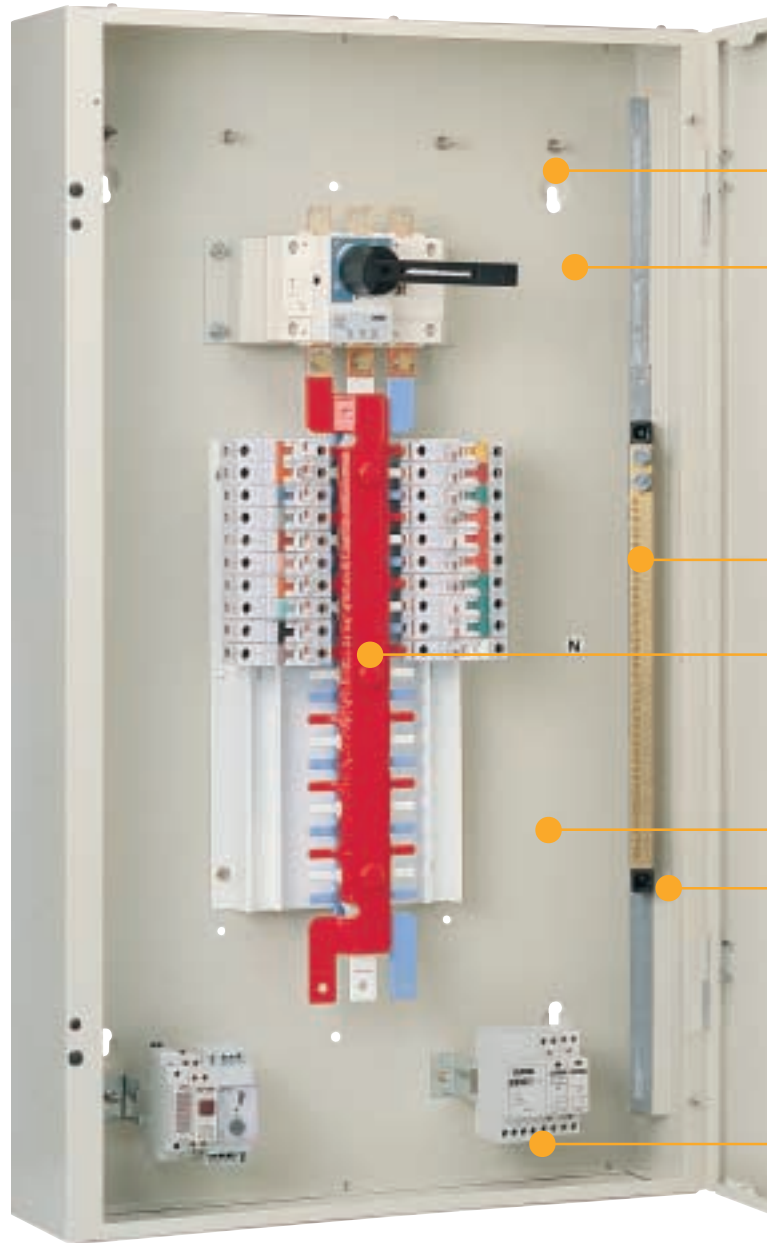

- Designed and manufactured in Australia for Australian conditions.
- Includes key hole slots for easy mounting.
- Extension boxes available for mounting of fault current limiters and up to 40 modules of DIN rail switchgear.

Note: 4 Series Power Range accessories not included.

and industrial applications

Features

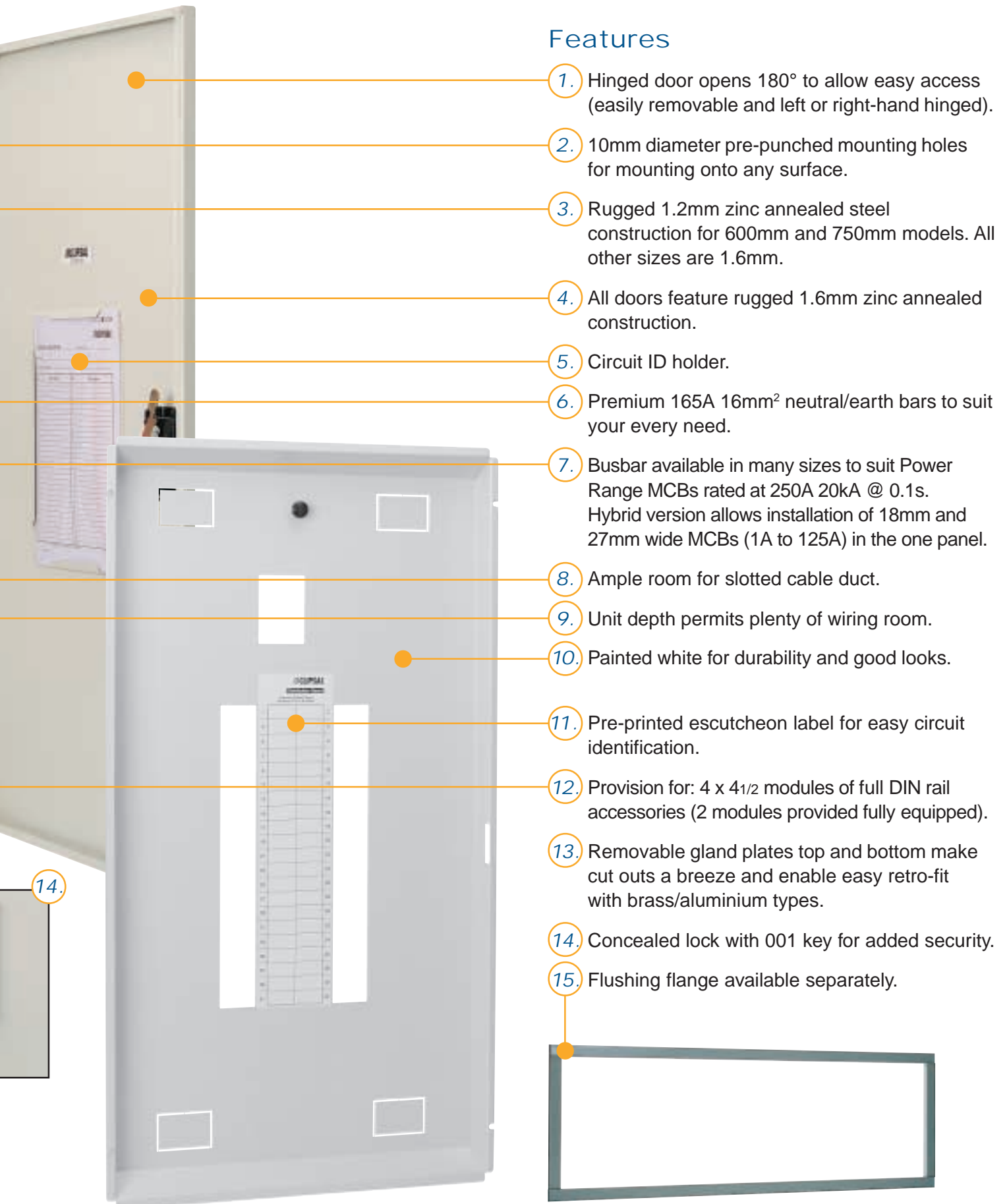

1. Hinged door opens 180° to allow easy access (easily removable and left or right-hand hinged).
2. 10mm diameter pre-punched mounting holes for mounting onto any surface.
3. Rugged 1.2mm zinc annealed steel construction for 600mm and 750mm models. All other sizes are 1.6mm.
4. All doors feature rugged 1.6mm zinc annealed construction.
5. Circuit ID holder.
6. Premium 165A 16mm² neutral/earth bars to suit your every need.
7. Busbar available in many sizes to suit Power Range MCBs rated at 250A 20kA @ 0.1s. Hybrid version allows installation of 18mm and 27mm wide MCBs (1A to 125A) in the one panel.
8. Ample room for slotted cable duct.
9. Unit depth permits plenty of wiring room.
10. Painted white for durability and good looks.
11. Pre-printed escutcheon label for easy circuit identification.
12. Provision for: 4 x 4 1/2 modules of full DIN rail accessories (2 modules provided fully equipped).
13. Removable gland plates top and bottom make cut outs a breeze and enable easy retro-fit with brass/aluminium types.
14. Concealed lock with 001 key for added security.
15. Flushing flange available separately.



4CXXM Series Metal Consumer Switchboard

Catalogue No. Pole Capacity Length Neutral and Earth
No Main Switch

4C18M	18	600	2 x 3/8" Bolt	18 x 16mm ² Tunnel
4C24M	24	600	"	24 x 16mm ² Tunnel
4C30M	30	750	"	30 x 16mm ² Tunnel
4C36M	36	750	"	36 x 16mm ² Tunnel
4C42M	42	950	"	42 x 16mm ² Tunnel
4C48M	48	950	"	48 x 16mm ² Tunnel
4C60M	60	950	"	60 x 16mm ² Tunnel
4C72M	72	1200	"	72 x 16mm ² Tunnel
4C84M	84	1200	"	84 x 16mm ² Tunnel

160A Main Switch

4C18M160	18	750	"	18 x 16mm ² Tunnel
4C24M160	24	750	"	24 x 16mm ² Tunnel
4C36M160	36	950	"	36 x 16mm ² Tunnel
4C48M160	48	1200	"	48 x 16mm ² Tunnel
4C60M160	60	1200	"	60 x 16mm ² Tunnel

250A Main Switch

4C30M250	30	950	"	30 x 16mm ² Tunnel
4C36M250	36	950	"	36 x 16mm ² Tunnel
4C48M250	48	1200	"	48 x 16mm ² Tunnel
4C60M250	60	1200	"	60 x 16mm ² Tunnel
4C72M250	72	1500	"	72 x 16mm ² Tunnel
4C84M250	84	1500	"	84 x 16mm ² Tunnel

160A Main Switch Hybrid

	Pole Capacity		Total	Length	Neutral and Earth	
	18mm	27mm				
4C24M160H	18	6	24	750	2 x 3/8"	24 x 16mm ² Tunnel
4C30M160H	24	6	30	950	"	30 x 16mm ² Tunnel
4C36M160H	30	6	36	950	"	36 x 16mm ² Tunnel
4C42M160H	30	12	42	1200	"	42 x 16mm ² Tunnel
4C48M160H	36	12	48	1200	"	48 x 16mm ² Tunnel
4C60M160H	48	12	60	1200	"	60 x 16mm ² Tunnel

250A Main Switch Hybrid

4C72M250H	60	12	72	1500	"	72 x 16mm ² Tunnel
-----------	----	----	----	------	---	-------------------------------

Flush Kits

	Description
4C1FK	Flush Kit suits 600H Consumer Board
4C2FK	Flush Kit suits 750H Consumer Board
4C3FK	Flush Kit suits 950H Consumer Board
4C4FK	Flush Kit suits 1200H Consumer Board
4C5FK	Flush Kit suits 1500H Consumer Board

40 Module Extension Box

4C18MEB	Full DIN less neutral/earth bars	450H x 560W x 165D
---------	----------------------------------	--------------------

Extension Box to suit 200A BS Fuse

4CFMEB	450H x 560W x 165D
--------	--------------------

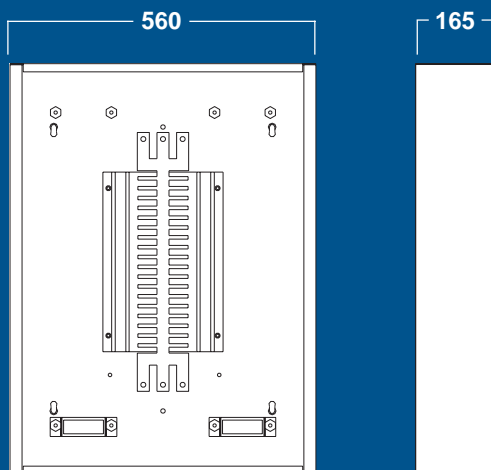

4C36M

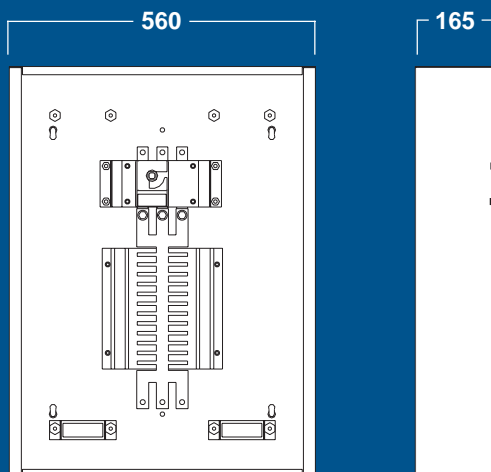

4C24M160

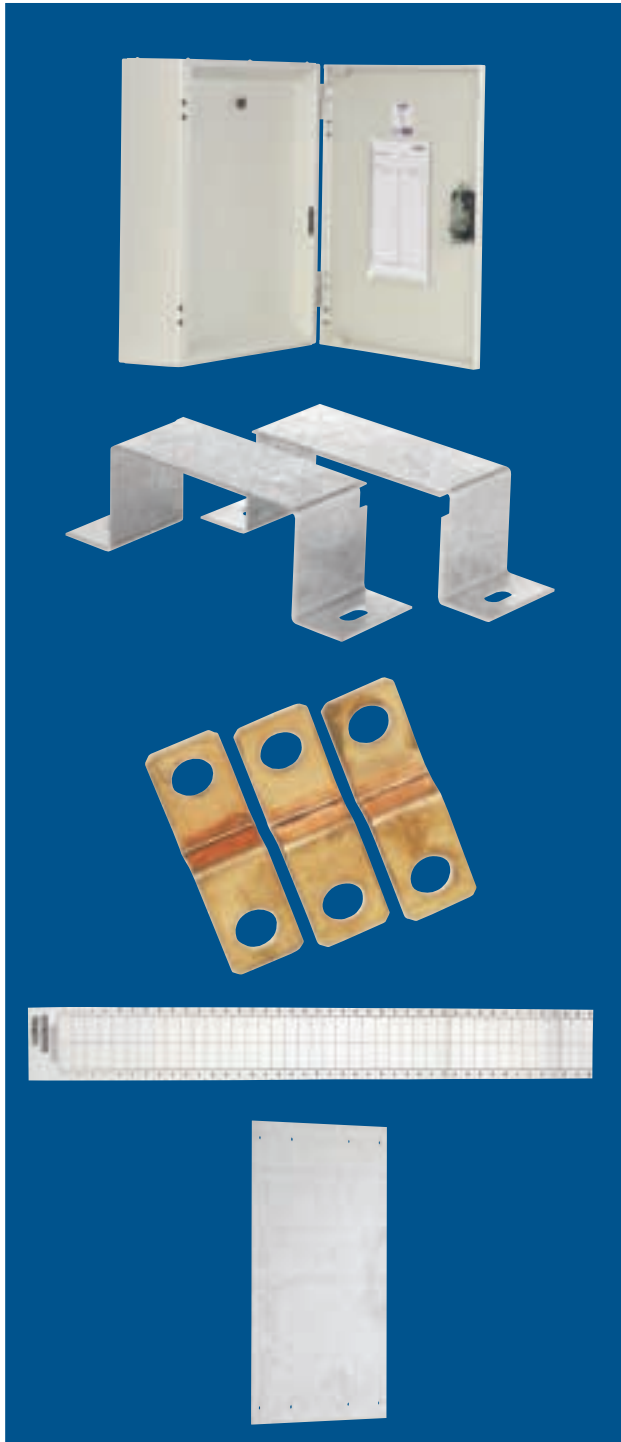

Metal Consumer Switchboard Accessories - Power Range

Cat No.	Description
4C1M	Size 1 (600 x 540 x 165) sheet steel enclosure only
4C2M	Size 2 (750 x 540 x 165) sheet steel enclosure only
4C3M	Size 3 (950 x 540 x 165) sheet steel enclosure only
4C4M	Size 4 (1200 x 540 x 165) sheet steel enclosure only
4C5M	Size 5 (1500 x 540 x 165) sheet steel enclosure only
4TH	Top hat suits full DIN 4.5 modules
4TH160	Top hat suits 160A 5 Series main switch
4TH250	Top hat suits 250A 5 Series main switch
4BT	Busbar tags to suit 250A M/S connection to chassis
4L	84 Pole legend sticker
4C1MP	Mounting pan suits size 1 enclosure
4C2MP	Mounting pan suits size 2 enclosure
4C3MP	Mounting pan suits size 3 enclosure
4C4MP	Mounting pan suits size 4 enclosure
4C5MP	Mounting pan suits size 5 enclosure

We cater for harsh commercial

4 SERIES

consumer switchboards

Now Clipsal fast fit boards are available as a premium heavy-duty type for commercial and harsh industrial environments.

Models from 24 to 84 poles are available with even more wiring room.

The products are made from durable zinc annealed steel 1.6mm in powdercoated grey. Because they've been designed and manufactured in Australia they're ideal for our tough conditions.



Easy installation.
Spacious interior.
Specials available.

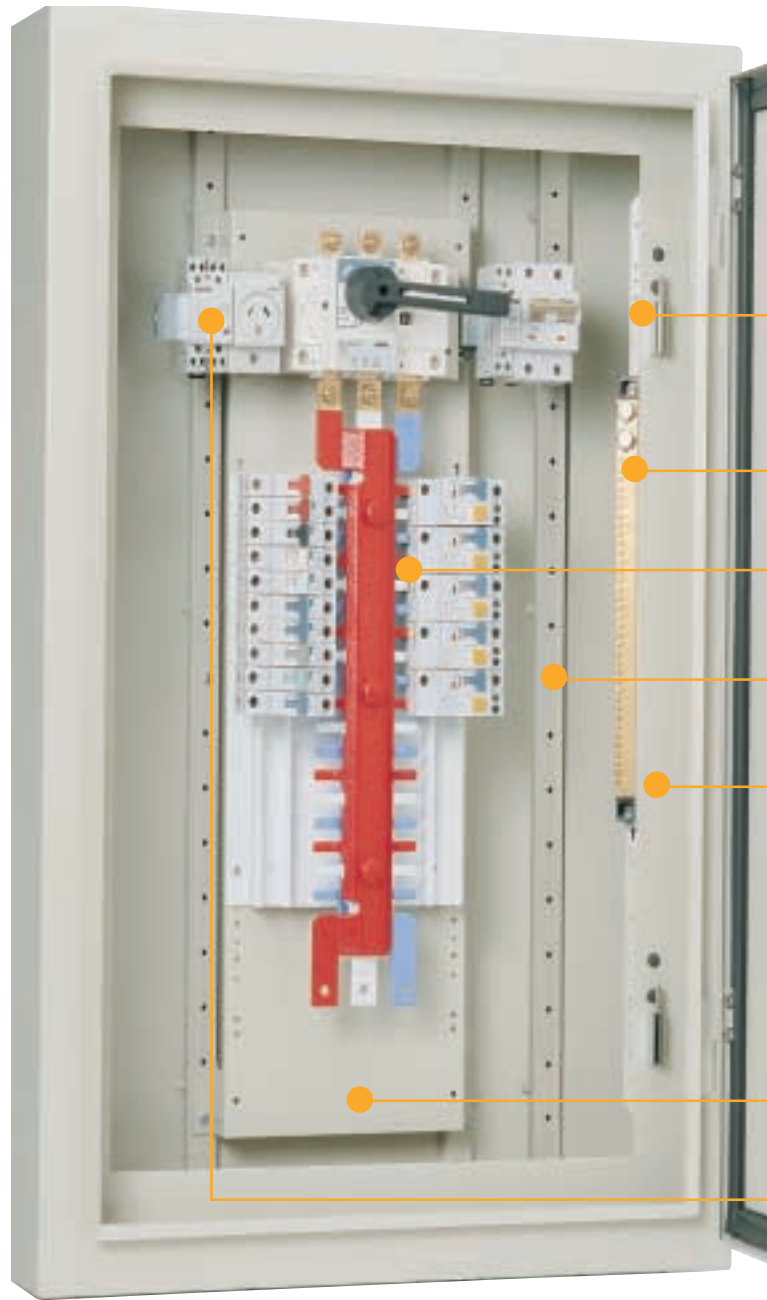

■ Designed and manufactured in Australia for Australian conditions.

Note: 4 Series Power Range accessories not included.



and industrial conditions too!

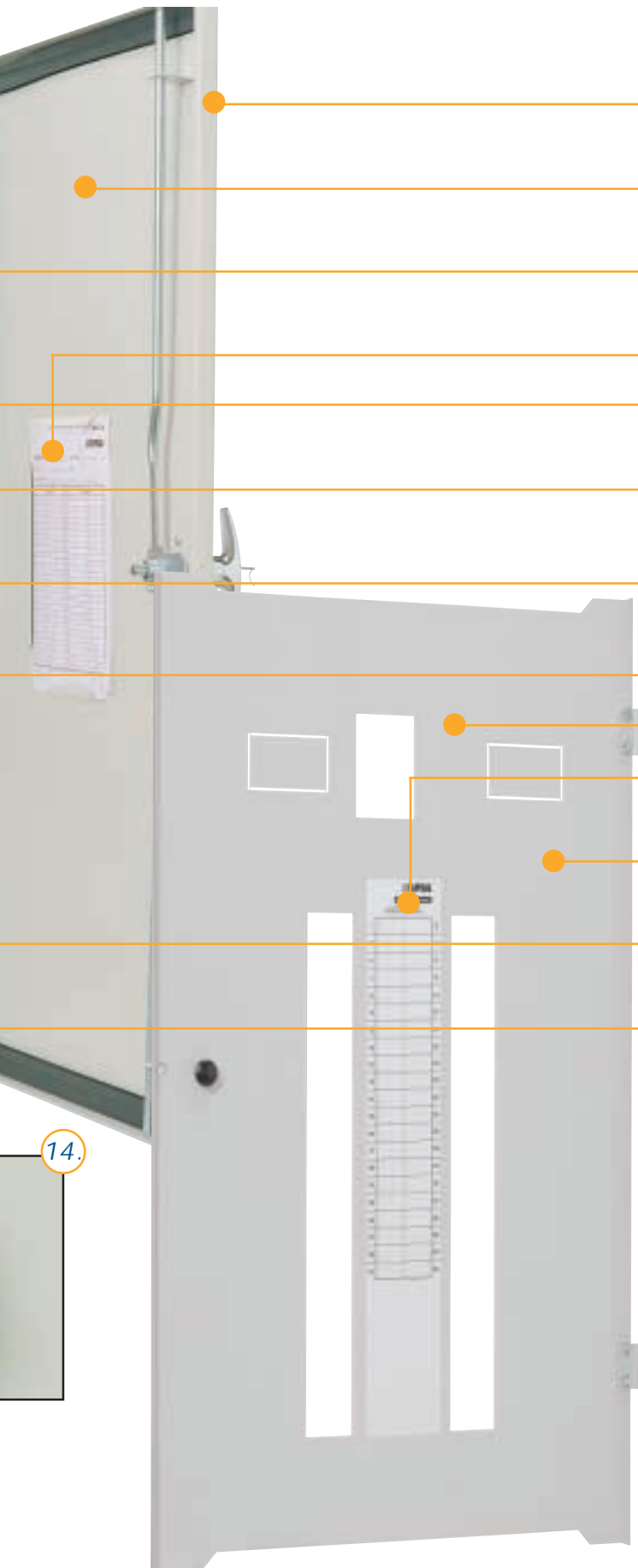

Features

1. Door folded and gasketed to ensure IP66 rating.
2. Hinged lift off door opens 180° to allow easy access.
3. Rugged 1.6mm zinc seam welded annealed steel.
4. Circuit ID holder.
5. Premium 165A 16mm² neutral/earth bars to suit your every need.
6. Busbar available in many sizes to suit Power Range MCBs rated at 250A 20kA @ 0.1s.
7. Ample room for slotted cable duct. Mounting rail for PVC duct so IP rating is not compromised.
8. Unit depth permits plenty of wiring room.
9. Painted white for durability and good looks.
10. Pre-printed escutcheon label for easy circuit identification.
11. Removable hinged escutcheon predrilled for IPA identification studs.
12. Space available under chassis for concealed cabling.
13. Provision for: 2 x 4 1/2 modules of full DIN rail accessories.
14. Chrome plated T-handle, 3 point locking 001 key for added security.
15. Gasketed removable gland plates top and bottom make cut outs a breeze and enable easy retro-fit with brass/aluminium types.
16. Flushing flange available separately.



4CWXXM Series IP66 Metal Consumer Switchboard

Catalogue No. Pole Capacity Length Neutral and Earth
No Main Switch

4CW24M	24	1080	2 x 3/8" Bolt	24 x 16mm ² Tunnel
4CW36M	36	1080	"	36 x 16mm ² Tunnel
4CW48M	48	1080	"	48 x 16mm ² Tunnel
4CW60M	60	1400	"	60 x 16mm ² Tunnel
4CW72M	72	1400	"	72 x 16mm ² Tunnel

160A Main Switch

4CW24M160	24	1080	"	24 x 16mm ² Tunnel
4CW36M160	36	1080	"	36 x 16mm ² Tunnel
4CW48M160	48	1080	"	48 x 16mm ² Tunnel
4CW60M160	60	1400	"	60 x 16mm ² Tunnel
4CW72M160	72	1400	"	72 x 16mm ² Tunnel

250A Main Switch

4CW36M250	36	1080	"	36 x 16mm ² Tunnel
4CW48M250	48	1080	"	48 x 16mm ² Tunnel
4CW60M250	60	1400	"	60 x 16mm ² Tunnel
4CW72M250	72	1400	"	72 x 16mm ² Tunnel
4CW84M250	84	1400	"	84 x 16mm ² Tunnel

Flush Kits

	Description
4CW1FK	Flush Kit suits 1080H Consumer Board
4CW2FK	Flush Kit suits 1400H Consumer Board

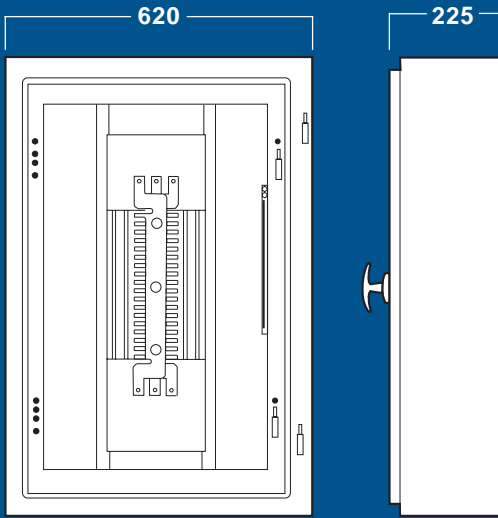

4CW36M

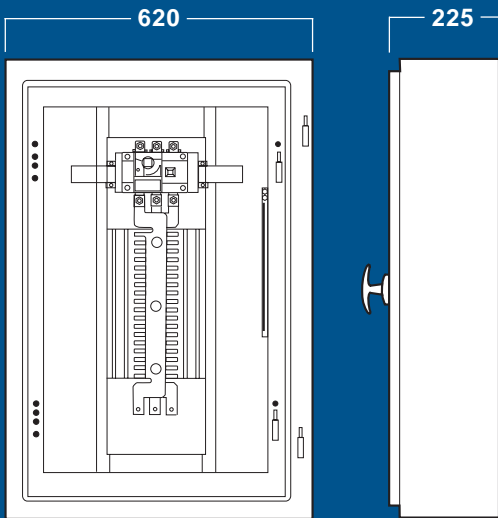

4CW36M160



Products of Gerard Industries Pty Ltd

ABN 27 007 873 529

Head Office

12 Park Terrace, Bowden
South Australia 5007
Telephone (08) 8269 0511
Facsimile (08) 8340 1724
Internet www.clipsal.com
Internet www.alfredonline.com.au
E-Mail plugin@clipsal.com.au

Offices in all States

NSW Sydney (02) 9794 9200
Albury (02) 6041 2377

VIC Melbourne (03) 9207 3200
Country areas 1800 653 893
QLD Brisbane (07) 3244 7444
Townsville (07) 4729 3333
SA Adelaide (08) 8269 0555
WA Perth (08) 9442 4444
TAS Hobart (03) 6272 3177
Launceston (03) 6331 6951
NT Darwin (08) 8947 0278

International Enquiries

Head Office Export Department
Telephone +61 8 8269 0587
Facsimile +61 8 8340 7350
E-Mail export@clipsal.com.au

New Zealand

Clipsal Industries (NZ) Ltd (Auckland)

Tel: (09) 576 3403
Fax: (09) 576 1015
E-Mail headoffice@clipsal.co.nz

Customer Service

Free Fax (0508) 250 305
Auckland/Mobile Phone (09) 572 0014
Free Phone (0508) CLIPSAL

2 547 7 2 5